

**Precision Punches,
Pilots,
Die Buttons,
& Retainers**

Versatile



Global leader in
providing fabrication
and stamping solutions

a MISUMI Group Company

www.daytonlamina.com

**Better
performance,
longer runs,
less downtime**



TEL. 81 8354 8910
www.acatmexicana.com

Versatile Precision Products

Product Applications

Versatile Punches, Pilots, Die Buttons, and Retainers are built to exact tolerances and concentricity to provide superior alignment, better performance, longer runs, and less downtime. Dayton Versatile products are considered "top-of-the-line" by regular users, and are mainstays in heavy industries with high-demand applications, such as automotive and major appliance manufacturing.

Versatile punches and die buttons provide three times better alignment than other major brands, thus assuring longer runs and better part performance. Versatile die buttons with tapered relief have no overhand and no step (unlike conventional counter-bored relief); provide positive slug control; and never fail due to lack of support of the cutting edge.

Dayton's Versatile precision product line includes: *Jektole® Punches (slug ejection punches); Regular Punches; Regular Pilots; Positive Pick-Up Pilots; Compact Positive Pick-Up Pilots; Straight and Blank Punches; Clospace Punches; Die Buttons; Retainers; Guide Bushings; and others, including Quill Bushings, Micro Guides, Misfeed Detectors, and Locking Devices.* Standard sizes and standard alterations are shown in this catalog within individual product sections.

Dayton Slug Control is a guaranteed method for reducing the risk of pulling slugs to the die surface during withdrawal of the punch. A series of grooves is designed inside the die buttons (see drawing). There, the slugs are trapped until they fall freely through the relief. The use of Dayton Slug Control has no effect on hole size, and will not require any changes in current regrind practices.

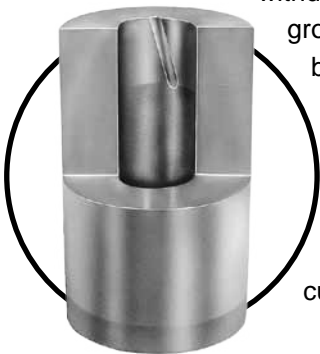

Ordering Information

Each page contains detailed instructions on how to order specific Dayton Versatile products. Individual drawings show product shape, dimensions, tolerances, and concentricity. When ordering, you are asked to specify quantity, type, shank and length codes (for example), and other applicable data.

In the example below, the type specified is "VPR." "V" stands for Versatile, "P" stands for punch, and "R" stands for rectangle. 37 is the press-fit diameter, which is coded by the first two digits of the decimal equivalent (.375"). 12 is the shank length, which is coded by inches and quarter-inches (one inch and two quarters). 23 is the overall length, coded by inches and quarter-inches. Finally, P.1875 and W.1325 represent the point or hole size dimensions.

HOW TO ORDER

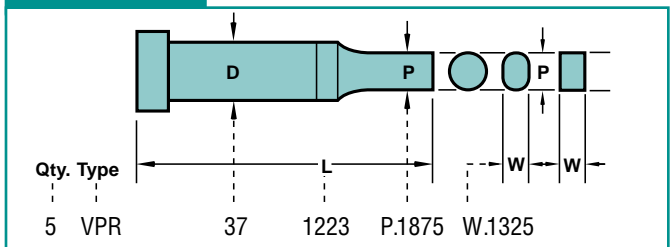

Standard Alterations

Punches, pilots, and die buttons are available in sizes other than those listed in the catalog.

When ordering, you are asked to specify different designations for various non-standard dimensions. For example, if the P and W dimensions are outside the standard range, an "X" is placed in front of the P or W dimension, e.g., "XP" and/or "XW." If the point length is other than standard, designate "XB" for the point length. See the foldout tabs in the individual product sections for these and other special order designations.

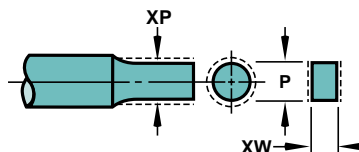

Contents

Punches

Standard Shapes

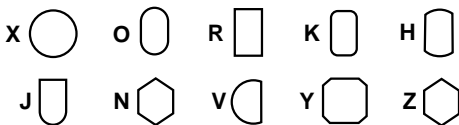

VJ_ Jektole® 4, 5



VP_ Regular 6, 7



VPT Pilots 8, 9



VPA Pilots 10, 11



VUAC/VPAC Pilots 12, 13



VJB/VPB Blanks 14, 15



VYX/VUX Straight 16



CloSPACE 17

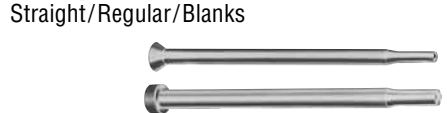

VJ_/VP_ Extended Range 28



Die Buttons

VN_/VR_ Die Buttons 18



KD_/KH_ EDM Button Blanks 19



Retainers

VRP Retainers 20



VRT/VRTS Retainers 21



Bushings/Guides

VG/VF/VE Guide Bushings 24



Bushings/Guides (cont'd)

MEX/MFX/MGX Micro Guides 25



MDX/MHX Micro Buttons 25



VQX/VFQ Quill Bushings/Guides 26



Miscellaneous/Other

Classified Shapes 22, 23

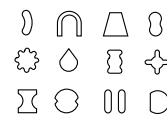

Shear Angles 29

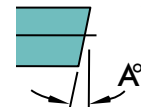

Locking Devices 30, 31

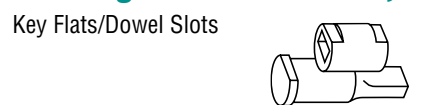

Form Shapes 32, 33

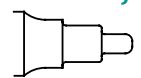

Jektole® Data 34

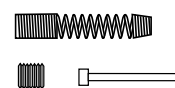

Product Designation

Each page contains detailed instructions on how to order specific Dayton Versatile products. In addition, use the following chart to define the product as a part number.

Example:

VPR Line Product Shape V for Versatile P for Punch (Regular) R for Rectangle

37 Press-Fit Dia. D (shank diameter) Coded by the first 2 digits of dec. equiv. (.375).

12 Shank Length Coded by inches and quarter-inches (1 inch and 2 quarters).

23 Overall Length L Coded by inches and quarter-inches (2 inches and 3 quarters).

Product Series Length Point or Hole Size
 VPR 37 1223 P.1875, W.1325
 Type Catalog Number Dimensions As Specified

Diameter (D) is shown on the order as a two- or three-digit code. To convert the shank diameter to the appropriate code, use the following chart.

Code	D	Code	D	Code	D
12	.1250	50	.5000	150	1.5000
18	.1875	62	.6250	175	1.7500
25	.2500	75	.7500	200	2.0000
31	.3125	87	.8750	225	2.2500
37	.3750	100	1.0000	250	2.5000
43	.4375	125	1.2500		

Classified Shapes

Classified shapes (83 common shapes, no detailing required) are available on all punches, solid die buttons, and guide bushings as indicated in this catalog. See pp. 22, 23 for more information and special instructions. Also, see individual product pages and pp. 30, 31 for additional information on orientation and views.

Clearance

Normal grinding methods produce:

- .007 max fillet on the punch — matching corner shape on the die button.
- .007 max fillet on the die button — matching corner shape on the punch.

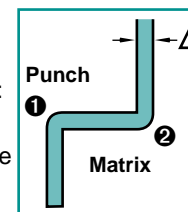

Compact Positive Pick-Up Pilots

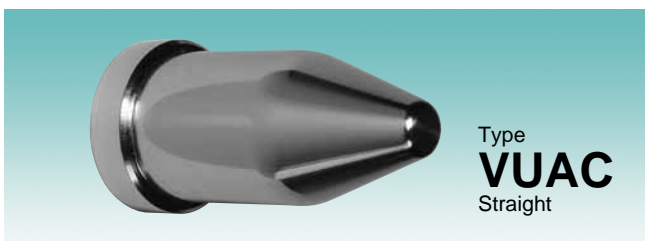

Type
VUAC
Straight

Material
Steel: A2, M2 (RC 60-63), PS (RC 63-65)

Type	Head H	Range P	N	*L							
				.625	.750	.875	1.00	1.125	1.250	1.375	
VUAC Straight	.375	.1865 - .2500	.25								
	.438	.2501 - .3130	.31								
	.500	.3131 - .3750	.37	62							
	.562	.3751 - .4380	.43								
	.625	.4381 - .5000	.50								
	.750	.5001 - .6250	.62		75	87	100	112	125	137	
	.875	.6251 - .7500	.75								
	1.000	.7501 - .8750	.87								
	1.125	.8751 - 1.0000	1.00								

*Any length is available within catalog range. Specify "XL" and length.

HOW TO ORDER

Specify:	Qty.	Type	D Code	L	P	Alt.	Steel
Example:	25	VUAC	—	75	.4380	XL.695	A2
	11	VPAC	62	100	.6200	—	A2



Standard Alterations

Versatile compact positive pick-up pilots are available in sizes other than those shown in the charts on pp. 12, 13.

When ordering, you are asked to specify different designations for various non-standard dimensions. For example, if the P dimension is outside the standard range, an "X" is placed in front of the P dimension, e.g., "XP." If the L₁ (VPAC only) is other than standard, designate "XBR" as the variable length. Also see "Standard Alterations" on the front of the pullout tab in this section for other special order designators.

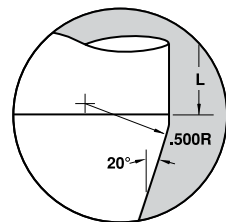
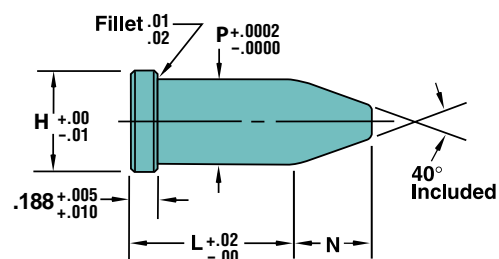

Compact Positive Pick-Up Pilots



Type
VPAC
Pointed

Material
Steel: A2, M2 (RC 60-63), PS (RC 63-65)

Type	Shank D	Code	Head H	Min. XP	Range P	*N	Pn	**L						
								.625	.750	.875	1.00	1.125	1.250	1.375
VPAC Pointed	.2500	25	.375	.092	.1500 - .2499	.25	.1432							
	.3125	31	.438	.092	.1870 - .3124	.31	.1883							
	.3750	37	.500	.092	.2250 - .3749	.37	.2342	62						
	.4375	43	.562	.092	.2650 - .4374	.43	.2793							
	.5000	50	.625	.124	.3000 - .4999	.50	.3252		75	87	100	112	125	137
	.6250	62	.750	.234	.3750 - .6249	.62	.4162							
	.7500	75	.875	.299	.4500 - .7499	.75	.5072							
	.8750	87	1.000	.349	.5250 - .8749	.87	.5982							
	1.0000	100	1.125	.399	.6000 - .9999	1.00	.6892							

*N = [(P-.057)/.728]+.132 when "P" dimension is less than "Pn" shown in chart.

**Any length is available within catalog range. Specify "XL" and length. The L₁.12 is maintained. Because L₁.12 is standard, use alteration code "XBR" for different length (0.060 min.).

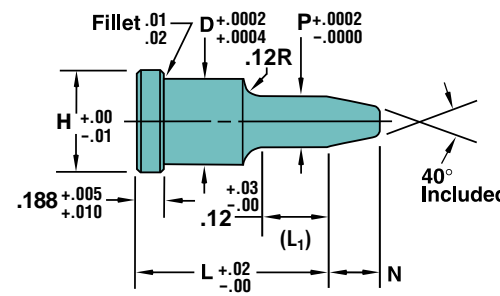

P to D .0003

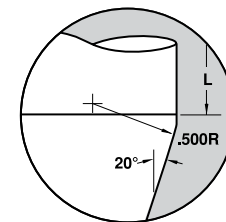

Features/Benefits

Dayton Versatile Compact Positive Pick-Up Pilots—mounted in a guided stripper—provide exceptional resistance to lateral deflection. A typical longer pilot may have several inches of exposed, unsupported surface. As bending or forming takes place, this lateral deflection can create excessive force on the pilot. Sometimes, the strength of the pilot—as well as the function of the other die set components—can be compromised.

Dayton Compact Pilots provide virtually no unsupported surface that is susceptible to sideways movement, stress, or wear. Pilots always maintain the proper extension, and there is no need to move or adjust the pilot during regrinding.

Dayton Compact Pilots are rigid during use; last longer; and are ideally suited for high-demand applications.

Standard Alterations Compact Pilots

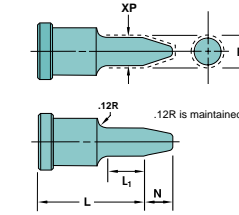

XP P Dimension Smaller than Standard

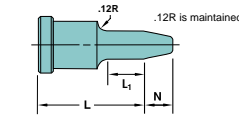

XBR L₁ Longer than Standard

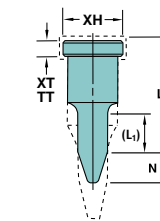

XL "L" Shortened
Stock removal from point end. L₁ length is maintained.

XT Thinner Head than Standard
Stock removal from head end which shortens overall length.

TT Precision Head Thickness
Same as XT except head thickness tolerance is held to ±.0005.

XH Reduced Head Diameter
Minimum head diameter equals H +.000 - .001.

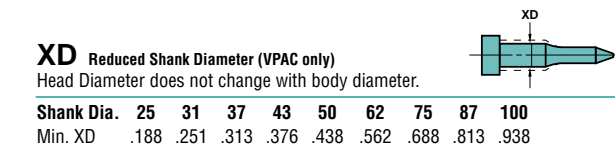

XD Reduced Shank Diameter (VPAC only)
Head Diameter does not change with body diameter.

Shank Dia.	25	31	37	43	50	62	75	87	100
Min. XD	.188	.251	.313	.376	.438	.562	.688	.813	.938

Surface Coatings & Treatments

Some catalog products can be coated to increase hardness, reduce galling, and improve wear and/or corrosion resistance.

DayTride® (XN)—a low-cost surface application that treats all exposed surfaces. Ideal for punches and die buttons. Provides high dimensional stability. Approx. hardness: RC73.

DayTiN® (XNT)—applied via PVD (physical vapor deposition). Provides extreme hardness (hard as carbide) and excellent lubricity when used with a lubricant. Not recommended for stainless steel, copper, or nickel. Approx. hardness: *Vickers 2300.

DayTAN™ (XAN)—ultra-hard, high-aluminum PVD coating. Absorbs shear stress and provides high temperature resistance. Ideal for HSLA, dual phase, and TRIP steels. Approx. hardness: *Vickers 3400.

TiCN (XCN)—very hard PVD, thin film. Provides ultra hardness (harder than carbide) and superior abrasive wear resistance. Approx. hardness: *Vickers 3000.

XNM—PVD, solid film. Produces lower coefficient of friction than other coatings. Provides excellent lubricity. Approx. hardness: *Vickers 2000.

XNP—the ultimate coating for extrusion and forming applications. Also works well in shaving operations. Tolerance is ±.0002. Approx. hardness: *Vickers 3100.

DayKool™ (XCR)—cryogenic steel conditioning process, used primarily with hard, thick materials. Improves strength, toughness, and dimensional stability.

CrN (CRN)—excellent adhesion, high toughness, and good corrosion resistance. Primary applications are metal forming (copper, brass, bronze), metal die casting, and plastic injection molding. Approx. hardness: *Vickers 1800-2100.

ZertonPlus™ (XNA)—excellent wear resistance, thermal shock stability and hot hardness. Approx. hardness *Vickers 3200.

XNAProgress (XNAP)—ultra-hard PVD coating that absorbs shear stress; provides excellent high-temperature resistance. Ideal for stamping where tools are exposed to extreme stress profiles. A good alternative to TD coating without the dimensional changes associated with that process. Approx hardness: *Vickers 3200.

Diamond Like Carbon Coating (XCD)—combines high hardness with an extremely low coefficient of friction. Good protection against abrasive & adhesive wear. Approx. hardness *Vickers 5000.

Code / Delivery		Material
XN —DayTride®	+ 3 days	M2 & PS
XNT —DayTiN®	+ 3 days	M2 & PS
XAN —DayTAN™	+ 4 days	M2 & PS
XCN —TiCN	+ 3 days	M2 & PS
XNM	+12 days	M2 & PS
XNP	+ 8 days	M2 & PS
XCR —DayKool™	+ 1 day	M2 & PS
CRN	+ 7 days	M2 & PS
XNA —ZertonPlus™	+ 7 days	M2 & PS
XNAP —XNAProgress	+12 days	M2 & PS
XCD	+8 days	M2 & PS

* Vickers used when RC exceeds 80.
© DayTride and DayTiN are registered trademarks of Dayton Progress.
™ DayTAN, DayKool, and ZertonPlus are trademarks of Dayton Progress.

Punch Blanks

Jektole® & Regular

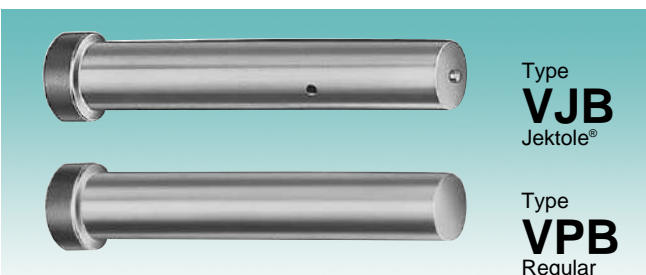

Type **VJB**
Jektole®

Type **VPB**
Regular

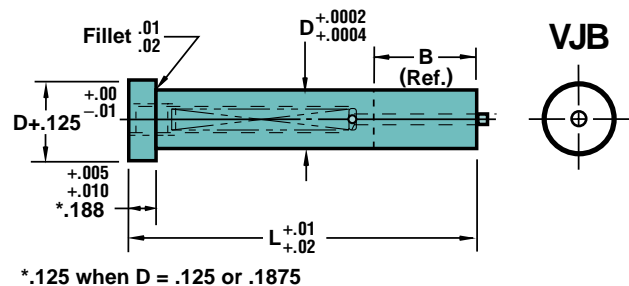

*.125 when D = .125 or .1875

Punch Blanks

Jektole® & Regular

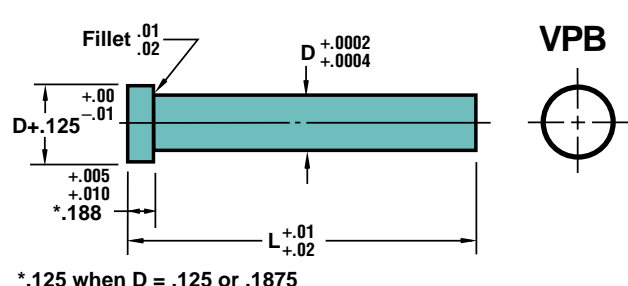

*.125 when D = .125 or .1875

Type	Shank		Point Lgth. B	L																Code	L								** Jektole® Group
	D	Code		1.25	1.50	1.75	2.00	2.25	2.50	2.75	3.00	3.25	3.50	3.75	4.00	4.25	4.50	4.75	5.00		5.25	5.50	5.75	6.00	6.25	6.50	6.75	7.00	
VJB	.1875	18	.50	0311	1012	1113	1220	1321	2022	2123	2230	2331	3032	3133	3240	3341	4042	4143	4250	4351	18	5052	5153	5260	5361	6062	J2		
	.2500	25																			25							J3	
	.3125	31																			J4								
	.3750	37																											J6
	.4375	43	.75	0312	1013	1120	1221	1322	2023	2130	2231	2332	3033	3140	3241	3342	4043	4150	4251	43	4352	5053	5160	5261	5362	J6			
	.5000	50																		50							J9		
	.6250	62																		J9									
	.7500	75																										J9	
	.8750	87	1.00	0313	1020	1121	1222	1323	2030	2131	2232	2333	3040	3141	3242	3343	4050	4151	43	4252	4353	5060	5162	5262	J6				
	.5000	50																	50							J9			
	.6250	62																	J9										
	.7500	75																									J9		
.8750	87	1.25	0320	1021	1122	1223	1330	2031	2132	2233	2340	3041	3142	3243	3350	4051	43	4152	4253	4360	5061	5162	J6						
.5000	50																50							J9					
.6250	62																J9												
.7500	75																								J9				
.8750	87	1.50	0321	1022	1123	1230	1331	2032	2133	2240	2341	3042	3143	3250	3351	43	4052	4153	4260	4361	5062	J6							
.5000	50															50							J9						
.6250	62															J9													
.7500	75																							J9					
.8750	87	N/A	125	150	175	200	225	250	275	300	325	350	375	400	425	450	475	500	525	43	550	575	600	625	650	675	700	N/A	
.5000	50																			50									N/A
.6250	62																			N/A									
.7500	75																												
.8750	87	N/A	N/A	N/A	N/A	N/A	N/A	N/A	N/A	N/A	N/A	N/A	N/A	N/A	N/A	N/A	N/A	N/A	N/A	N/A	N/A	N/A	N/A	N/A	N/A	N/A	N/A	N/A	N/A

**See p.32 for additional information.

Standard Alterations

Punch Blanks

Material
Steel: A2, M2, PS4 (RC 60-63), PS (RC 63-65)
All heads are drawn to RC 40-55.

Features/Benefits

Dayton Punch Blanks are an ideal cost-effective alternative in applications where Dayton standard shape configurations or our classified shapes do not meet customer requirements. Blanks—available in a full range of standard lengths from 1.25" to 7.00"—can be custom-ground to meet virtually any customer requirement.

HOW TO ORDER

Specify:	Qty.	Type	D Code	L	Steel
Example:	4	VJB	50	1020	A2
	3	VPB	37	200	M2



Surface Coatings & Treatments

Some catalog products can be coated to increase hardness, reduce galling, and improve wear and/or corrosion resistance.

DayTride® (XN)—a low-cost surface application that treats all exposed surfaces. Ideal for punches and die buttons. Provides high dimensional stability. Approx. hardness: RC73.

DayTiN® (XNT)—applied via PVD (physical vapor deposition). Provides extreme hardness (hard as carbide) and excellent lubricity when used with a lubricant. Not recommended for stainless steel, copper, or nickel. Approx. hardness: *Vickers 2300.

DayTAN™ (XAN)—ultra-hard, high-aluminum PVD coating. Absorbs shear stress and provides high temperature resistance. Ideal for HSLA, dual phase, and TRIP steels. Approx. hardness: *Vickers 3400.

TiCN (XCN)—very hard PVD, thin film. Provides ultra hardness (harder than carbide) and superior abrasive wear resistance. Approx. hardness: *Vickers 3000.

XNM—PVD, solid film. Produces lower coefficient of friction than other coatings. Provides excellent lubricity. Approx. hardness: *Vickers 2000.

XNP—the ultimate coating for extrusion and forming applications. Also works well in shaving operations. Tolerance is ± .0002. Approx. hardness: *Vickers 3100.

DayKool™ (XCR)—cryogenic steel conditioning process, used primarily with hard, thick materials. Improves strength, toughness, and dimensional stability.

CrN (CRN)—excellent adhesion, high toughness, and good corrosion resistance. Primary applications are metal forming (copper, brass, bronze), metal die casting, and plastic injection molding. Approx. hardness: *Vickers 1800-2100.

ZertonPlus™ (XNA)—excellent wear resistance, thermal shock stability and hot hardness. Approx. hardness *Vickers 3200.

XNAProgress (XNAP)—ultra-hard PVD coating that absorbs shear stress; provides excellent high-temperature resistance. Ideal for stamping where tools are exposed to extreme stress profiles. A good alternative to TD coating without the dimensional changes associated with that process. Approx hardness: *Vickers 3200.

Diamond Like Carbon Coating (XCD)—combines high hardness with an extremely low coefficient of friction. Good protection against abrasive & adhesive wear. Approx. hardness *Vickers 5000.

Code / Delivery	Material
XN —DayTride® + 3 days	M2 & PS
XNT —DayTiN® + 3 days	M2 & PS
XAN —DayTAN™ + 4 days	M2 & PS
XCN —TiCN + 3 days	M2 & PS
XNM +12 days	M2 & PS
XNP + 8 days	M2 & PS
XCR —DayKool™ + 1 day	M2 & PS
CRN + 7 days	M2 & PS
XNA —ZertonPlus™ + 7 days	M2 & PS
XNAP—XNAProgress +12 days	M2 & PS
XCD +8 days	M2 & PS

* Vickers used when RC exceeds 80.
® DayTride and DayTiN are registered trademarks of Dayton Progress.
™ DayTAN, DayKool, and ZertonPlus are trademarks of Dayton Progress.

Standard Alterations

Punch Blanks

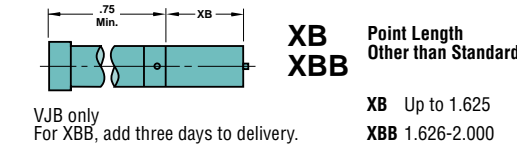

XD Reduced Shank Diameter
Head diameter does not change with body diameter.

Shank Dia.	18	25	31	37	43	50	62	75	87	100
Min. XD VJB	.172	.218	.282	.344	.376	.438	.562	.688	.813	.938
Min. XD VPB	.126	.188	.251	.313	.376	.438	.562	.688	.813	.938

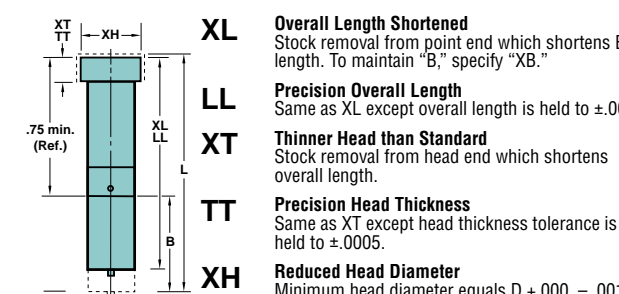

XTK Kommercial Head Thickness

Shank Dia. D	18	25	31	37	43	50	62	75	87	100
Thickness T	.125	.125	.125	.188	.188	.188	.250	.250	.250	.250

XK No Side Hole
For air ejection. No cost. VJB only

XJ Smaller Jektole Components
+3 days See p. 34. VJB only

See page 35 for Shear Angles.

Straight Punches

Jektol® and Regular

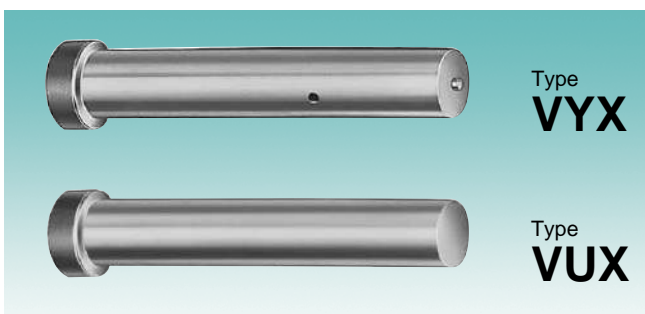

Material
Steel: A2, M2 (RC 60-63)
All heads are drawn to RC 40-55.
P Tolerance $\begin{matrix} +.0002 \\ -.0000 \end{matrix}$

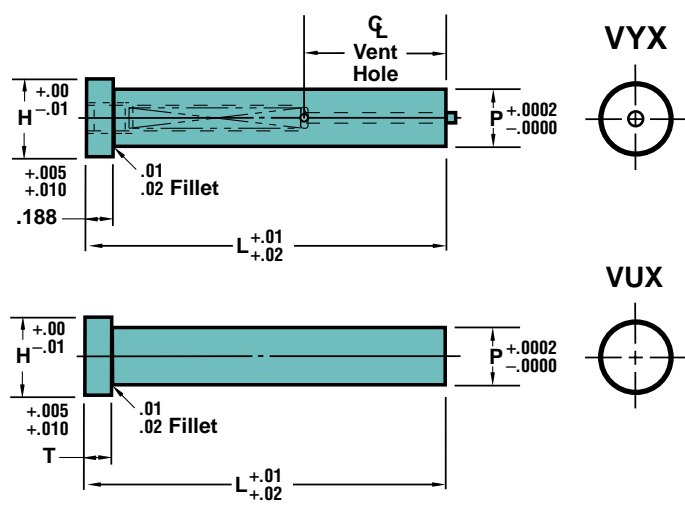

Type	Range P	Head Dia. H	Head Thk. T	Vent Hole	L																	* Jektol® Group					
					1.25	1.50	1.75	2.00	2.25	2.50	2.75	3.00	3.25	3.50	3.75	4.00	4.25	4.50	4.75	5.00	5.25		5.50	5.75	6.00	6.25	6.50
VYX	.1870-.2500	.375	See DWG.	.55	125	150	175	200	225	250	275	300													J2		
	.2501-.3130	.438		.55	125	150	175	200	225	250	275	300	325	350	375	400										J3	
	.3131-.3750	.500		.60	125	150	175	200	225	250	275	300	325	350	375	400										J4	
	.3751-.4380	.562		.85	150	175	200	225	250	275	300	325	350	375	400											J6	
	.4381-.5000	.625		1.10	150	175	200	225	250	275	300	325	350	375	400											J6	
	.5001-.6250	.750		1.10	150	175	200	225	250	275	300	325	350	375	400												J9
VUX	.0620-.1250	.250	N/A	.125	125	150	175	200	225	250	275	300	325	350	375	400										N/A	
	.1251-.1880	.312		.125	125	150	175	200	225	250	275	300	325	350	375	400										N/A	
	.1881-.2500	.375		.188	125	150	175	200	225	250	275	300	325	350	375	400	425	450	475	500						N/A	
	.2501-.3130	.438		.188	125	150	175	200	225	250	275	300	325	350	375	400	425	450	475	500	525	550	575	600	625	650	N/A
	.3131-.3750	.500		.188	125	150	175	200	225	250	275	300	325	350	375	400	425	450	475	500	525	550	575	600	625	650	N/A
	.3751-.4380	.562		.188	125	150	175	200	225	250	275	300	325	350	375	400	425	450	475	500	525	550	575	600	625	650	N/A

*See p.32 for additional information.

HOW TO ORDER

Specify:	Qty.	Type	P	L	Steel
Example:	5	VYX	P.324	250	A2
	2	VUX	P.492	325	M2

Standard Alterations

Versatile straight and clospace punches are available in sizes other than those shown in the chart above and on p.17.

When ordering, you are asked to specify different designations for various non-standard dimensions. For example, if the P dimension is outside the standard range, an "X" is placed in front of the P dimension, e.g., "XP." Also see "Standard Alterations" on the front of the pullout tab in this section for other special order designators.



Standard Alterations

Straight and Clospace Punches

Straight Punches

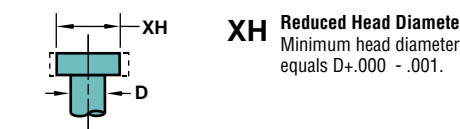
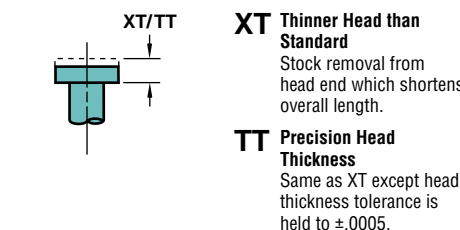
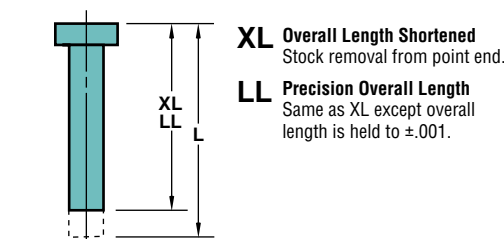

See page 35 for Shear Angles.

Clospace Punches

Alteration Code	Product					
	VXX	VWX	VCX	VVX	VCB	VVB
XB			●	●		
XD			●			
XH	●		●		●	
XL	●	●	●	●	●	●
LL	●	●	●	●	●	●
XP			●	●		
XT	●		●		●	
TT	●		●		●	

For an explanation of the alteration codes shown above, see the "Standard Alterations, Regular Punches" on the p.7 pullout tab.

Clospace Punches

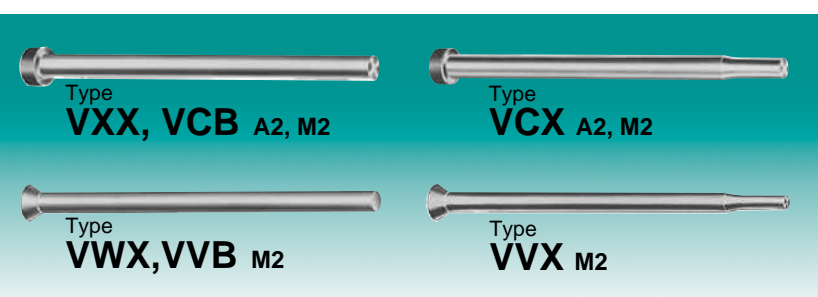

Material
Steel: A2, M2 (RC 60-63)
VXX, VCX, and VCB heads are drawn to RC 40-55.
P Tolerance $\begin{matrix} +.0002 \\ -.0000 \end{matrix}$
P to D $\begin{matrix} +.0003 \\ \text{⊙} \end{matrix}$

Straight Punches

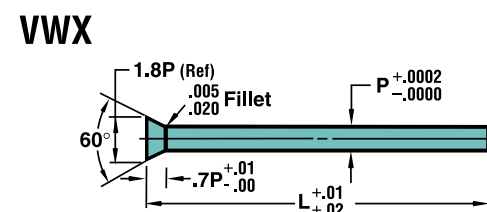
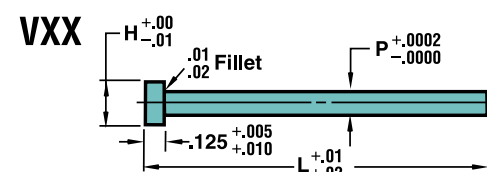

HOW TO ORDER

Specify:	Qty.	Type	D Code	L	P	Steel
Example:	5	VCX	12	200	P.098	M2

Type	Shank		Head Dia. H	Point Lgth. B	Range P	L																			
	D	Code				1.50	1.75	2.00	2.25	2.50	2.75	3.00	3.25	3.50	3.75	4.00									
Straight Punches VXX VWX			.125	N/A	.0300-.0500																				
			.125		.0501-.0630																				
			.160		.0631-.0940																				
		N/A	.190		.0941-.1250	150	175	200	225	250															
			.220		.1251-.1570						275	300	325	350	375	400									
			.250		.1571-.1880																				
Regular Punches VCX VVX			.282	.1881-.2190																					
			.313	.2191-.2500																					
	Punch Blanks VCB VVB		.0625	06	.125	.19	.0310-.0624																		
			.0938	09	.160	.25	.0626-.0937																		
			.1250	12	.190	.31	.0939-.1249																		
			.1562	15	.220	.31	.1251-.1561	150	175	200	225	250	275	300	325	350	375	400							
		.1875	18	.250	.31	.1563-.1874																			
		.2188	21	.282	.31	.1876-.2187																			

Regular Punches

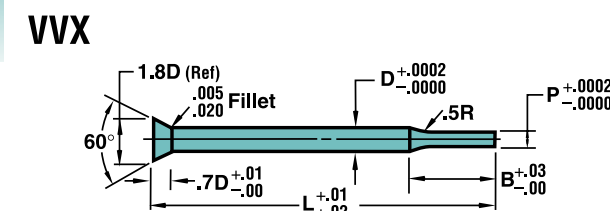
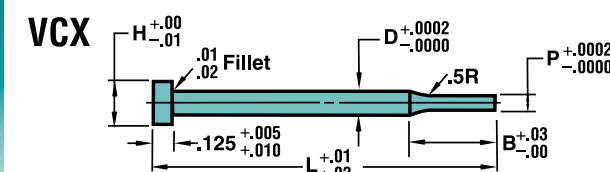

Punch Blanks

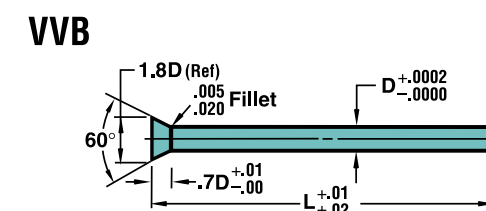
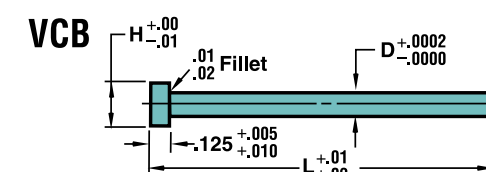

Surface Coatings & Treatments

Some catalog products can be coated to increase hardness, reduce galling, and improve wear and/or corrosion resistance.

DayTride® (XN)—a low-cost surface application that treats all exposed surfaces. Ideal for punches and die buttons. Provides high dimensional stability. Approx. hardness: RC73.

DayTiN® (XNT)—applied via PVD (physical vapor deposition). Provides extreme hardness (hard as carbide) and excellent lubricity when used with a lubricant. Not recommended for stainless steel, copper, or nickel. Approx. hardness: *Vickers 2300.

DayTAN™ (XAN)—ultra-hard, high-aluminum PVD coating. Absorbs shear stress and provides high temperature resistance. Ideal for HSLA, dual phase, and TRIP steels. Approx. hardness: *Vickers 3400.

TiCN (XCN)—very hard PVD, thin film. Provides ultra hardness (harder than carbide) and superior abrasive wear resistance. Approx. hardness: *Vickers 3000.

XNM—PVD, solid film. Produces lower coefficient of friction than other coatings. Provides excellent lubricity. Approx. hardness: *Vickers 2000.

XNP—the ultimate coating for extrusion and forming applications. Also works well in shaving operations. Tolerance is ± .0002. Approx. hardness: *Vickers 3100.

DayKool™ (XCR)—cryogenic steel conditioning process, used primarily with hard, thick materials. Improves strength, toughness, and dimensional stability.

CrN (CRN)—excellent adhesion, high toughness, and good corrosion resistance. Primary applications are metal forming (copper, brass, bronze), metal die casting, and plastic injection molding. Approx. hardness: *Vickers 1800-2100.

ZertonPlus™ (XNA)—excellent wear resistance, thermal shock stability and hot hardness. Approx. hardness *Vickers 3200.

XNAPProgress (XNAP)—ultra-hard PVD coating that absorbs shear stress; provides excellent high-temperature resistance. Ideal for stamping where tools are exposed to extreme stress profiles. A good alternative to TD coating without the dimensional changes associated with that process. Approx hardness: *Vickers 3200.

Diamond Like Carbon Coating (XCD)—combines high hardness with an extremely low coefficient of friction. Good protection against abrasive & adhesive wear. Approx. hardness *Vickers 5000.

Code / Delivery	Material
XN —DayTride® + 3 days	M2
XNT —DayTiN® + 3 days	M2
XAN —DayTAN™ + 4 days	M2
XCN —TiCN + 3 days	M2
XNM +12 days	M2
XNP + 8 days	M2
XCR —DayKool™ + 1 day	M2
CRN + 7 days	M2
XNA —ZertonPlus™ + 7 days	M2
XNAP—XNAPProgress +12 days	M2
XCD +8 days	M2

* Vickers used when RC exceeds 80.
© DayTride and DayTiN are registered trademarks of Dayton Progress.
™ DayTAN, DayKool, and ZertonPlus are trademarks of Dayton Progress.

Classified Shapes

Classified shapes (83 common shapes, no detailing required) are available on all punches, die buttons, and guide bushings, as indicated in this catalog. The 83 available common shapes are shown here and on p. 23. Also, see the outside of the pullout tab for notes and drawing references.

Ordering Information

*Corner Dimensions

Dimensions should be the theoretical sharp corners for shapes C22, C24, C34, C61, and C88. However, some reduction of these dimensions will result from fitting the punch and die button under conditions where the clearance is .0025 or less per side.

†Shape Center

Shapes are centered on the punch shanks as shown. Shapes in guide bushings and die buttons are also centered as shown with the exception of shapes C22 and C34. Due to clearance, the P dimension on these shapes will not be centered.

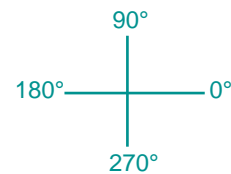

Flatted Rounds

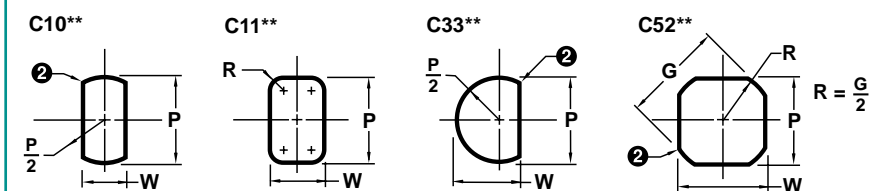

** Now standard. See product pages.

Classified Shapes

Classified Shapes Ordering Information

Reflected View— Punches and Guides

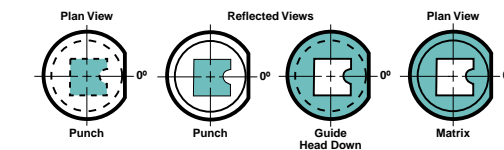

The reflected view is used for punches and guides. It is the view as seen in a mirror held below a punch or guide in its operating position. It is the same as a plan view from the head end, in which the point shape is shown dotted. A reflected view is shown with solid lines.

Orientation and Locking

The locking device orientation is standard at 0°. For types of locking methods and custom locations, see p. 30.

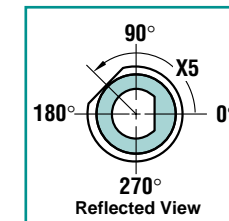

Clearance

Normal grinding methods produce ① .007 max fillet on the punch and ② .007 max fillet on the die button with matching corner shape on the die button and punch, respectively. When ordering die buttons, please specify punch dimensions and clearance per side (Δ). (If the clearance is .0025 Δ, Dayton will break sharp corners when the punches and die buttons are ordered together.)

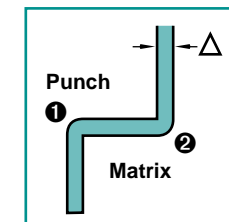

Mono Lobes

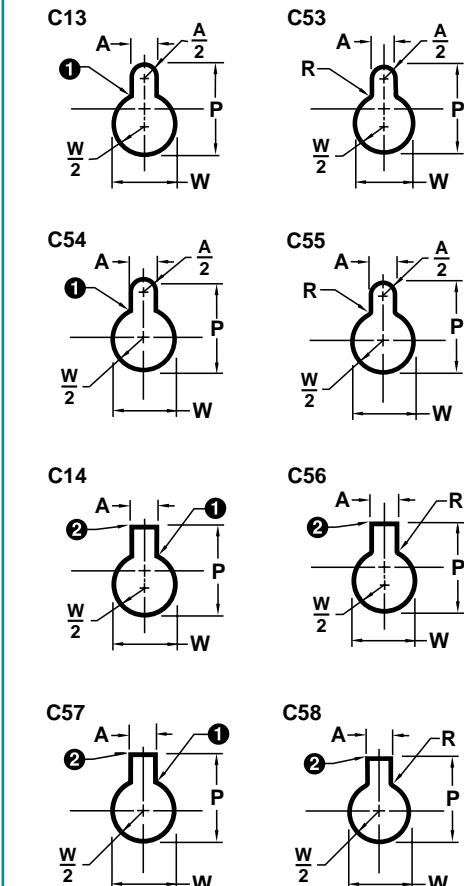

Multi Lobes

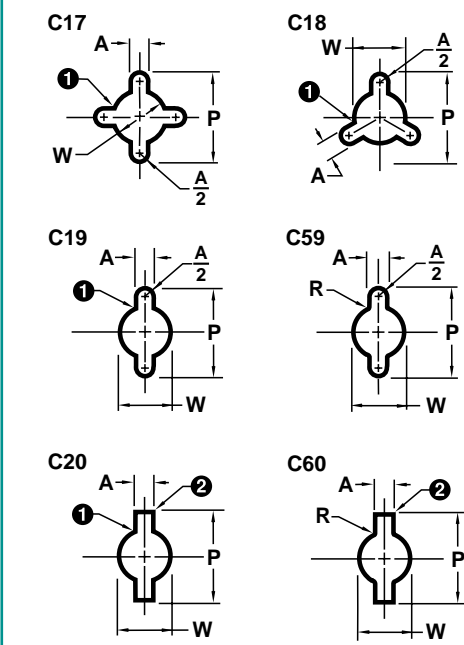

Miscellaneous

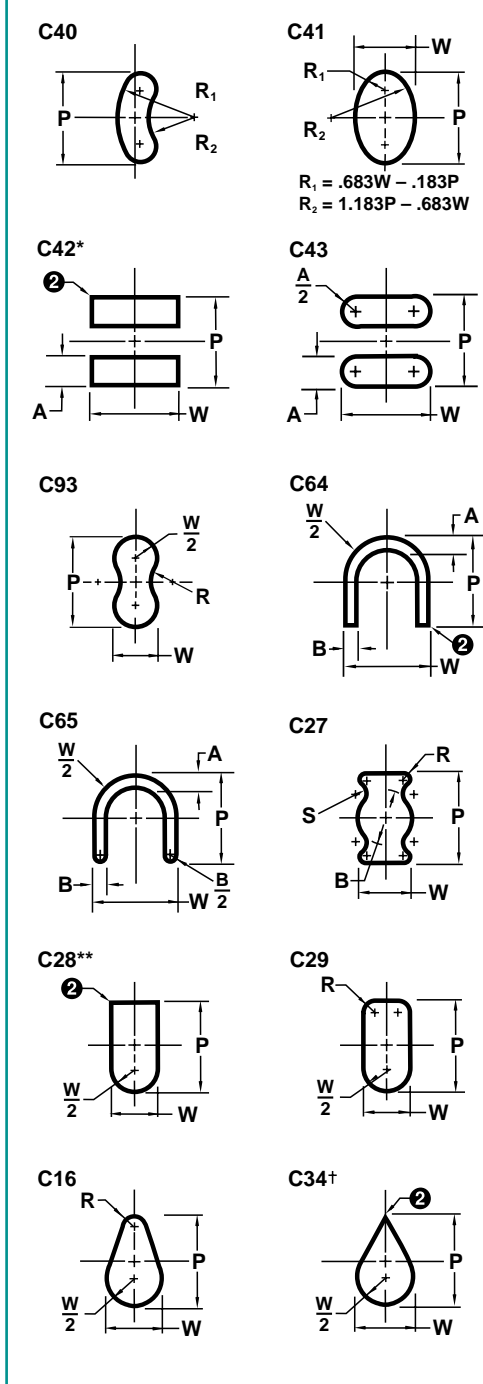

Us

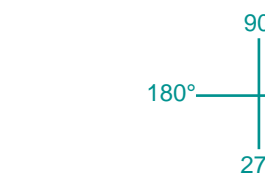
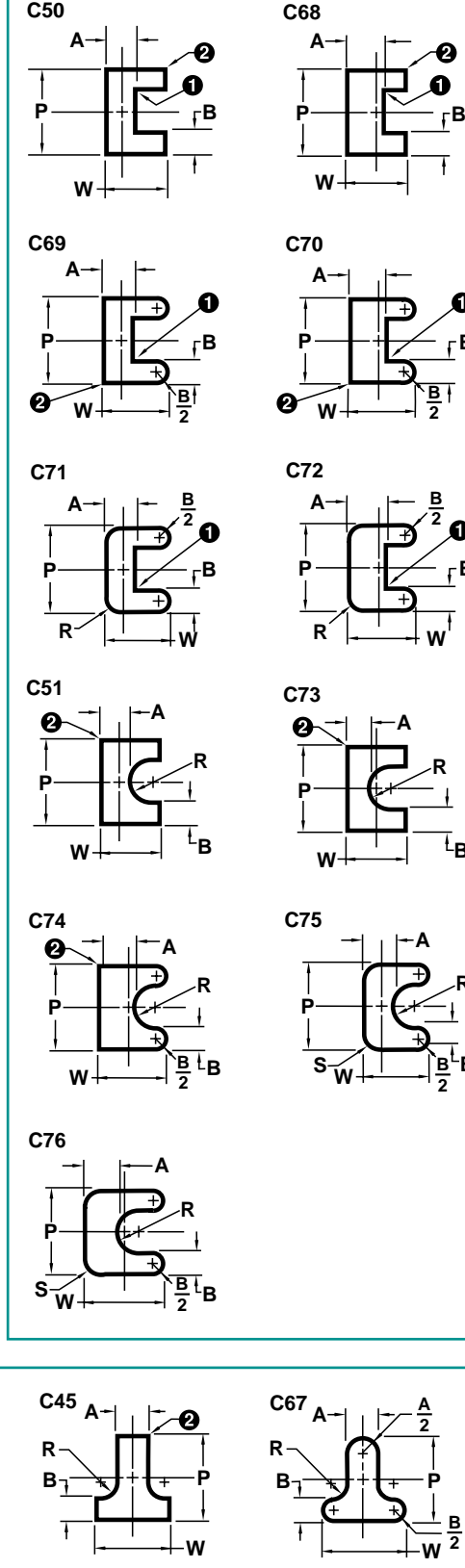

Ls

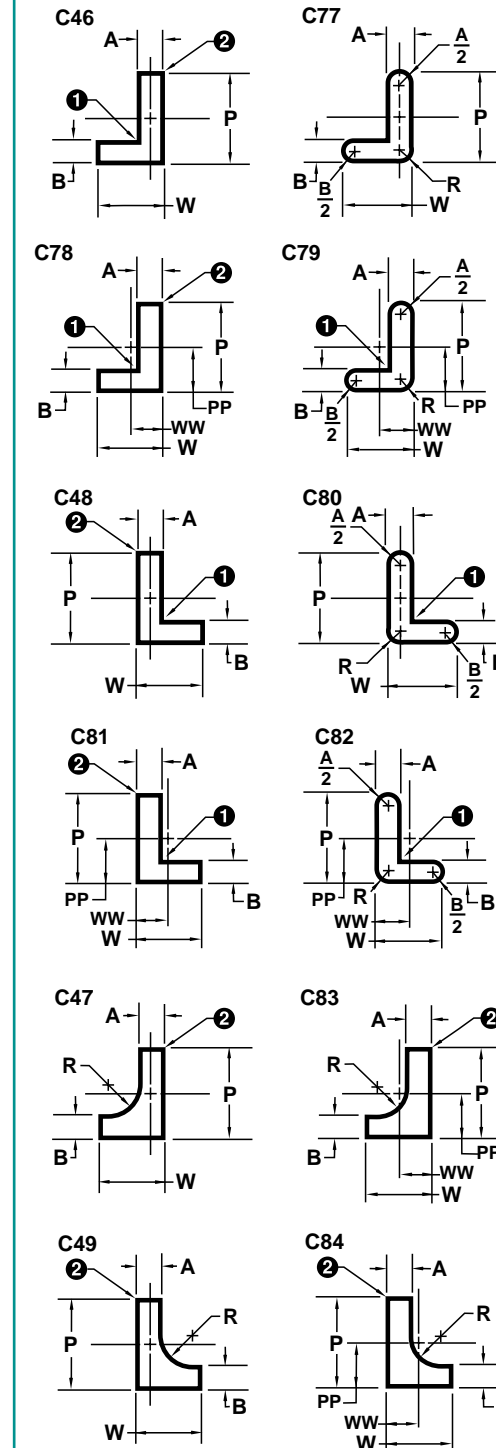

Polygons

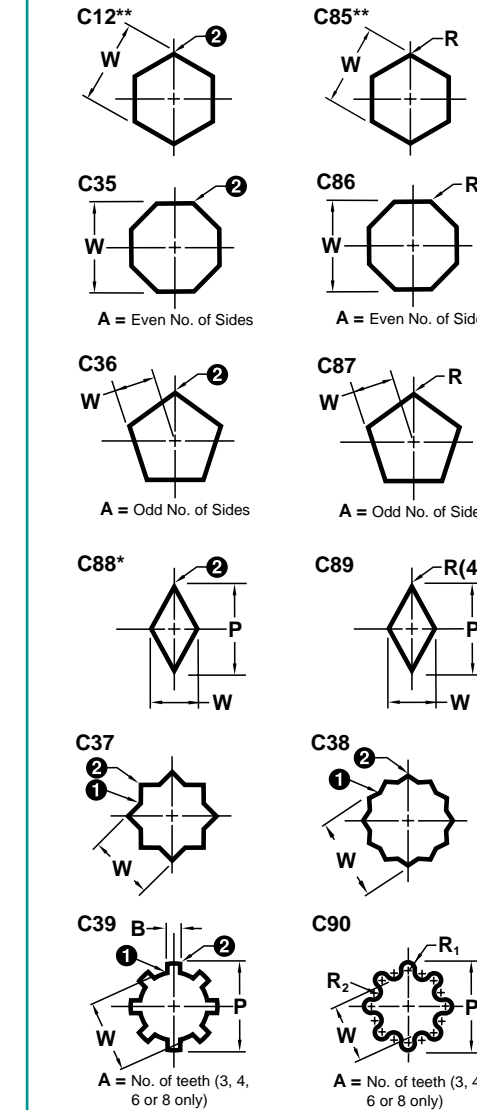

Duo Tees

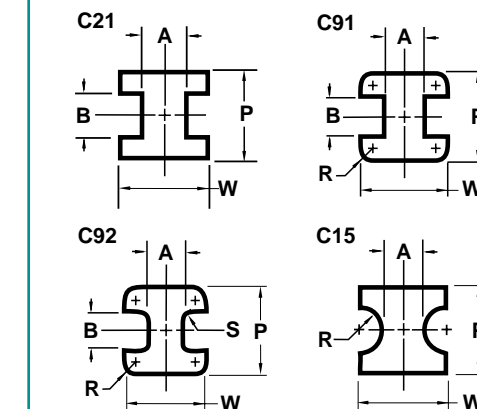

*See "Corner Dimensions" note on p. 22.

Guide Bushings

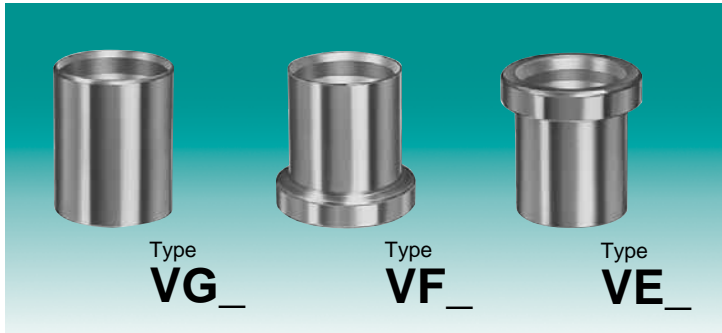

Material
 Steel: A2 (RC 60-63)
 P&W Tolerance $\pm .0002$ to $-.0000$
 P to D $.0003$

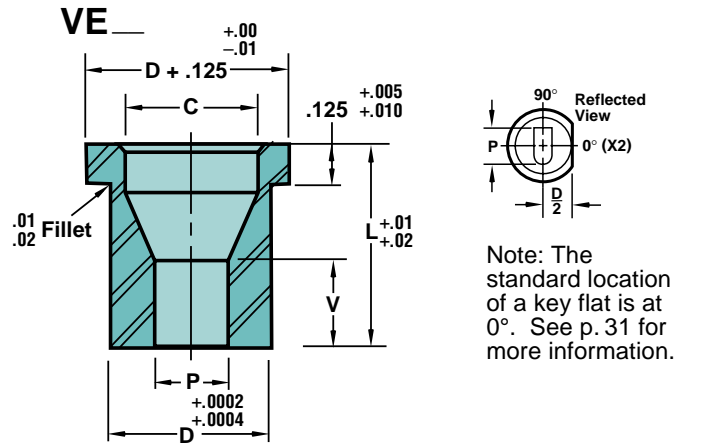
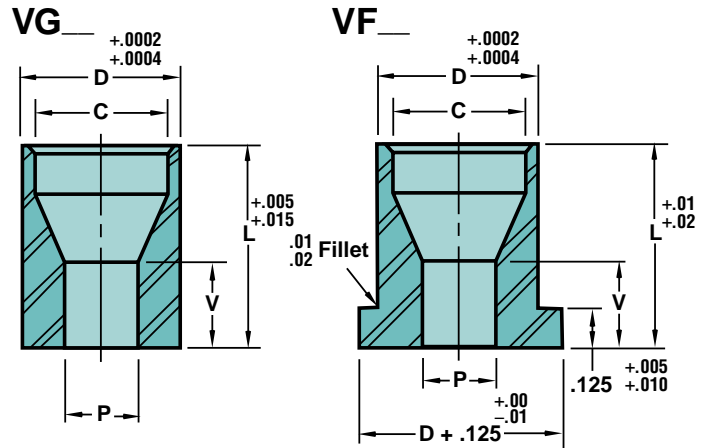

1 Check your P&W dimensions to be certain the diagonal G does not exceed the maximum shown.

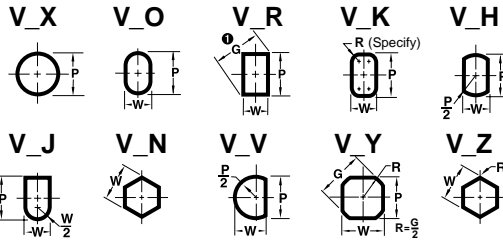

Note: The standard location of a key flat is at 0°. See p. 31 for more information.

	Body		Round	Shape		C' Bore Dia. C	L				
	D	Code		Range P	Min. W		Max. P/G	.3125	.3750	.5000	.6250
Headless VG	.1875	18	.062-.130	.050	.130	.141	31				
	.2500	25	.062-.170	.050	.170	.201					
	.3125	31	.093-.212	.050	.212	.261		37	50		
	.3750	37	.125-.255	.050	.255	.323					62
	.4375	43	.187-.297	.075	.297	.386					
	.5000	50	.212-.344	.075	.344	.448					
.6250	62	.293-.425	.075	.425	-						
Head Down VF	.1875	18	.062-.130	.050	.130	.141	31				
	.2500	25	.062-.170	.050	.170	.201					
	.3125	31	.093-.212	.050	.212	.261		37	50		
	.3750	37	.125-.255	.050	.255	.323					62
	.4375	43	.187-.297	.075	.297	.386					
	.5000	50	.212-.344	.075	.344	.448					
.6250	62	.293-.425	.075	.425	-						
Head Up VE	.1875	18	.062-.130	.050	.130	.141	31				
	.2500	25	.062-.170	.050	.170	.201					
	.3125	31	.093-.212	.050	.212	.261		37	50		
	.3750	37	.125-.255	.050	.255	.323					62
	.4375	43	.187-.297	.075	.297	.386					
	.5000	50	.212-.344	.075	.344	.448					
.6250	62	.293-.425	.075	.425	-						

Applications

Guide bushings should be ordered a minimum of .0005 larger than the punch point diameter with which they are to be used.

Alterations—Guide Bushings

Product	Rounds	Shapes
XH	●	●
XT	●	●
TT	●	●

For an explanation of the alteration codes shown above, see the "Standard Alterations, Regular Punches" on the p.7 pullout tab.

Guide Chart

Hole Range P or G	Land Length V
Up to .0650	2P
.0651-.0950	P + .065
.0951-.4250	.82P + .082

HOW TO ORDER

Specify:	Qty.	Type	Code	L	P (or P&W)
Example:	4	VEX	37	62	P.146
	2	VFO	50	50	P.250, W.075

Micro Guides/Die Buttons

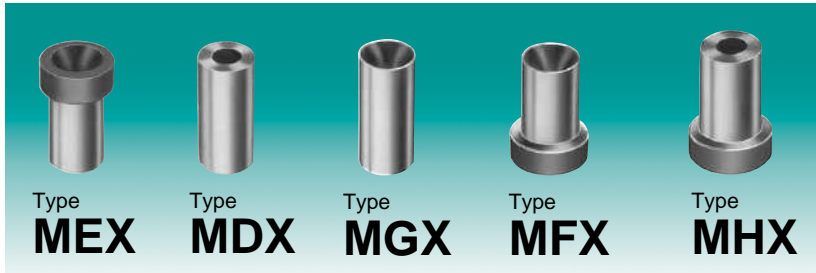

Material
 Steel: A2 (RC 60-63)
 P&W Tolerance $\begin{matrix} +.0002 \\ -.0000 \end{matrix}$
 P to D $\begin{matrix} .0003 \\ \text{⊗} \end{matrix}$



Guide Chart

Hole Range P	Land Length V
Up to .0650	2P
.0651-.0950	P + .065
.0951-.4250	.82P + .082

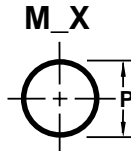
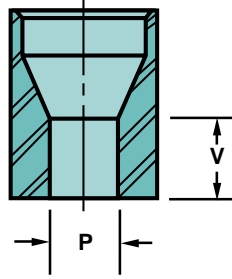

Guides

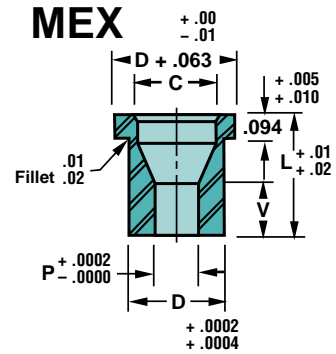

MGX

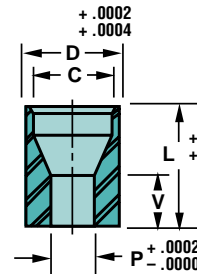

MFX

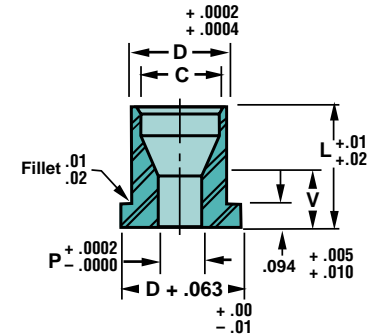

Die Buttons

	Body		Range P	C'Bore Dia. C	L			
	D	Code			.250	.3125	.375	.500
MGX Headless Guide	.1250	12	.031 - .062	.076	25	31	37	
	.1875	18	.046 - .130	.141		31	37	
MFX Head-Down Guide	.1250	12	.031 - .062	.076		31	37	
	.1875	18	.046 - .130	.141		31	37	
MEX Head-Up Guide	.1250	12	.031 - .062	.076		31	37	
	.1875	18	.046 - .130	.141		31	37	
MDX Headless Die Button	.1250	12	.031 - .062	N/A		31	37	50
	.1875	18	.046 - .130	N/A		31	37	50
MHX Headed Die Button	.1250	12	.031 - .062	N/A		31	37	50
	.1875	18	.046 - .130	N/A		31	37	50

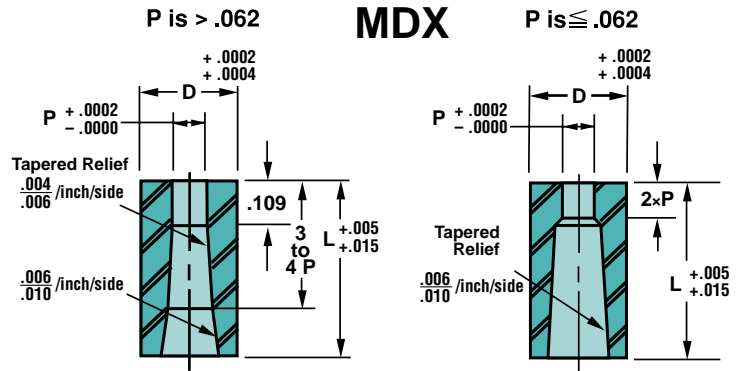

HOW TO ORDER

Specify:	Qty.	Type	Code	L	P (or P&W)
Example:	3	MEX	18	31	P.062
	3	MGX	12	31	P.044
	2	MFX	12	31	P.057
	3	MHX	18	37	P.060
	2	MDX	12	31	P.045

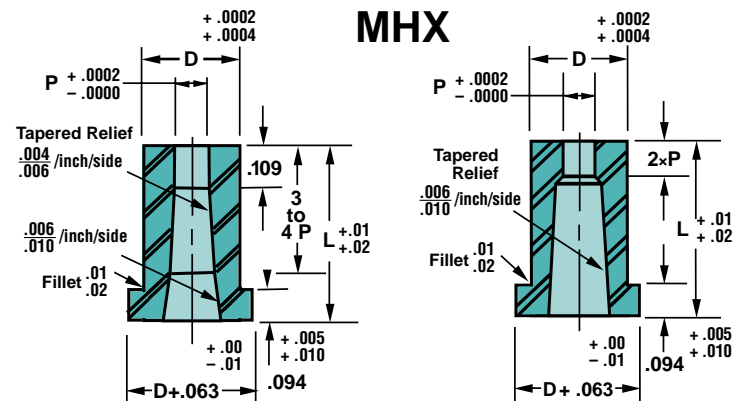

Quill Bushings/Guides

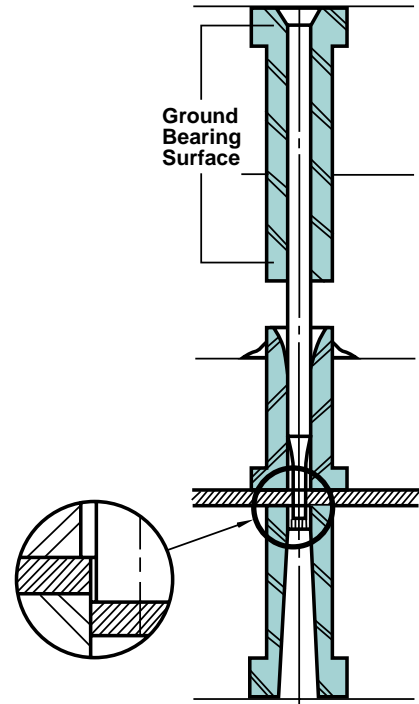
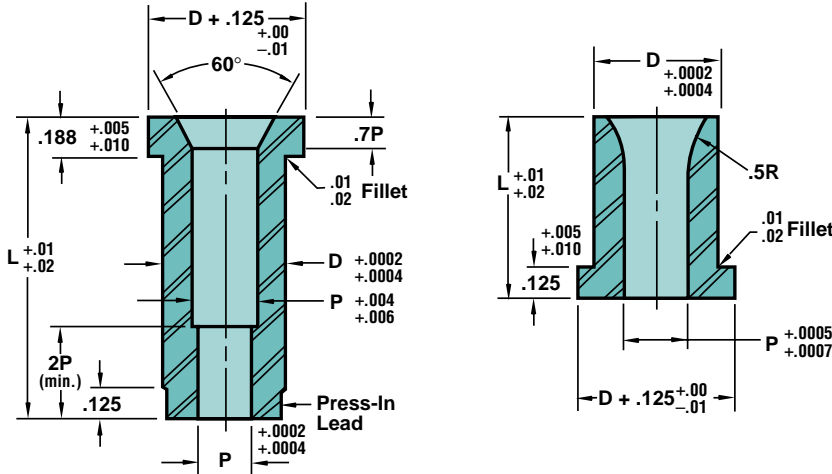
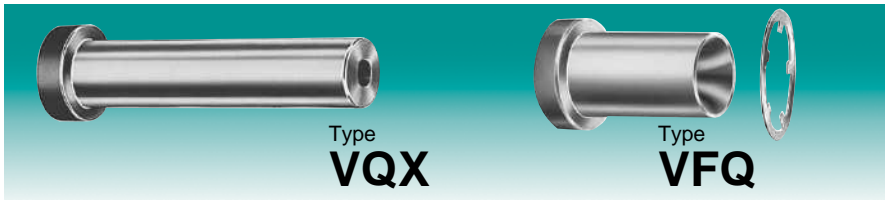

Material

Steel: A2 (RC 60-63)
Bearing: Bronze (VFQ)

Note: No alterations available on VFQ. VFQ, as shown above, comes complete with a halo washer that provides a head at both ends.

Matched Quill Sets

Matched Quill Sets are ideal for small hole applications where the risk of punch breakage is extremely high and where replacement costs must be considered.

Limitations

Body Code	XP		XD	
	Min. P	Max. P	Min. XD	Max. P
18	.0625	.094	.126	.0625
25	.0625	.125	.188	.0938
31	.0625	.156	.251	.1250
37	.0625	.188	.313	.1562
43	.0625	.219	.376	.1875

Quill Bushing Alterations

- XD** Reduced Shank Diameter
- XH** Reduced Head Diameter
- XL** Overall Length Shortened
- XP** P Dimensions Larger than Standard

Perfect Alignment

Ground bearings at both ends of the Quill Bushing assure precise punch-to-punch alignment. This eliminates the bending influence of unrelieved bushing holes, which are difficult to manufacture straight. Dayton manufactures products with a .002 to .003 relief per side between bearing surfaces, which eliminates this problem.

No Stock Distortion Risk

During stripping, the punch tends to pull the stock into the stripper void, which may cause part distortion. Dayton eliminates the distortion potential by manufacturing the product with a controlled limit, i.e., .015 per side maximum. Distortion cannot occur when the space between the guides and the punch (.5 D-P) is less than the stock thickness.

Body	D	Code	Punch Hole P	L				
				.500	.625	.750	1.000	1.250
VQX Press Fit Quill Bushings	.1875	18	.0625					
	.2500	25	.0938					
	.3125	31	.1250			75	100	125
	.3750	37	.1562					
	.4375	43	.1875					
VFQ Quill Guide Bushings	.1875	18	.0625	50				
	.2500	25	.0938		62			
	.3125	31	.1250					
	.3750	37	.1562			75		
	.4375	43	.1875					

HOW TO ORDER

Specify:	Qty.	Type	Code	L	Steel
Example:	3	VQX	31	75	A2
	4	VFQ	31	75	Bearing Bronze



VersaPlus® Premium Products

Precision, High-Performance Punches and Pilots

VersaPlus® Punches and Pilots are a premium line of precision, high-performance products that offer more features and benefits to users in industries where higher-than-normal production runs occur—and where optimum performance is a MUST.

VersaPlus® is “setting the new standard in high performance,” according to tool companies and manufacturers who have field-tested the products. For example, a furniture hardware manufacturer realized a production run improvement from 250,000 to 375,000—a 150% increase. In another test, a tool and die company increased run-time-to-sharpening from 100,000 pieces to 200,000.

VersaPlus® gives users the real “plus” through improved production capabilities, increased uptime, and lower costs.

For additional information or a copy of our latest VersaPlus® catalog, contact your Dayton Progress Distributor.



Extended Range Punches

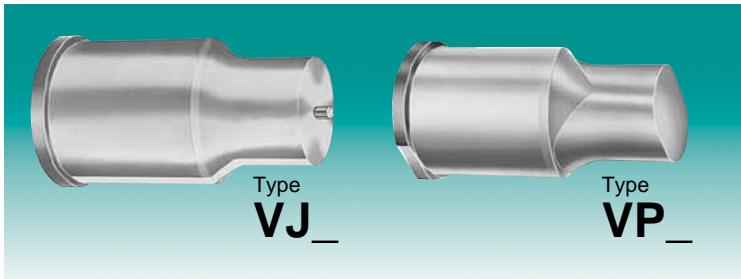

Shown here with optional key flat. See p. 31.

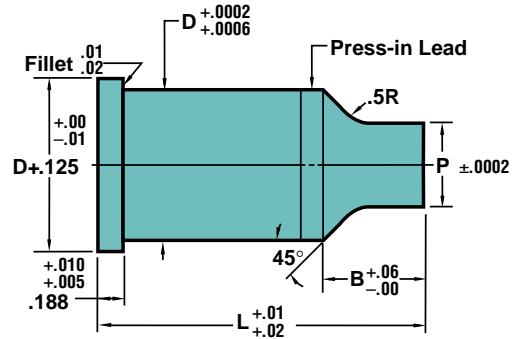

When D-P exceeds .406 a step will exist.

Material

Steel: A2, M2, PS4 (RC 60-63)
 P&W Tolerance ±.0002
 P to D $\frac{.0003}{\text{M}}$



HOW TO ORDER

Specify:	Qty.	Type	Shank	L	P (or P&W)	Steel
Example:	3	VPR	200	1021	P1.206, W.582	M2

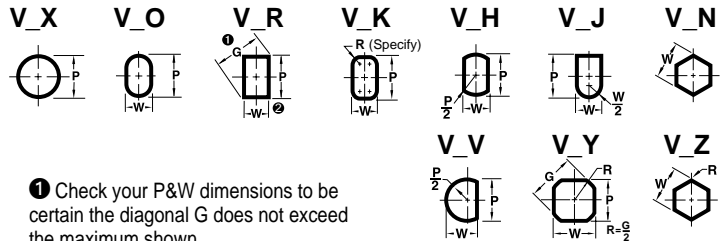

1 Check your P&W dimensions to be certain the diagonal G does not exceed the maximum shown.

2 Sharp corners are typical. To assure proper clearance, Dayton will provide standard broken corners to eliminate interference with die button fillet when total clearance is .005 or less.

Shank D	Point Lgth. B	Round Range P	Shape Min. W Max. P/G	L																	Jektol® Group			
				2.25	2.50	2.75	3.00	3.25	3.50	3.75	4.00	4.25	4.50	4.75	5.00	5.25	5.50	5.75	6.00	6.25		6.50	6.75	7.00
1.250	1.25	.625-1.2499	.282-1.2500																				J12	
1.500		.750-1.4999	.300-1.5000																					J12
1.750		1.000-1.7499	.350-1.7500	1021	1122	1223	1330	2031	2132	2233	2340	3041	3142	3243	3350	4051	4152	4253	4360	5061	5162	5263	5370	J12
2.000		1.187-1.9999	.400-2.0000																					J12
2.250		1.375-2.2499	.450-2.2500																					J12
2.500		1.625-2.4999	.500-2.5000																					J12
1.250	1.50	.625-1.2499	.282-1.2500																				J12	
1.500		.750-1.4999	.300-1.5000																				J12	
1.750		1.000-1.7499	.350-1.7500		1022	1123	1230	1331	2032	2133	2240	2341	3042	3143	3250	3351	4052	4153	4260	4361	5062	5163	5270	J12
2.000		1.187-1.9999	.400-2.0000																					J12
2.250		1.375-2.2499	.450-2.2500																					J12
2.500		1.625-2.4999	.500-2.5000																					J12

*See p.30 for more details.

Surface Coatings

Code / Delivery	Material
XN —DayTride®	+ 3 days M2 & PS4
XNT —DayTiN®	+ 3 days M2 & PS4
XAN —DayTAN™	+ 4 days M2 & PS4
XCN —TiCN	+ 3 days M2 & PS4
XNM	+12 days M2 & PS4
XNP	+ 8 days M2 & PS4
XCR —DayKool™	+ 1 day M2 & PS4
CRN	+ 7 days M2 & PS4
XNA —ZertonPlus™	+ 7 days M2 & PS4
XNAP—XNAPProgress	+12 days M2 & PS4
XCD	+8 days M2 & PS4

For more information on Dayton Progress surface coatings, see the back of the pullout tab on p. 5.

® DayTride and DayTiN are registered trademarks of Dayton Progress.
 ™DayTAN and DayKool are trademarks of Dayton Progress.

Shear Angles

Shear Angles can be applied to all punch points. These angles are used primarily to reduce slug pulling. Single and Double Shears can be used to reduce the punching force as well as minimize slug pulling. These alterations are prepriced and do not add to the standard delivery of the product.

Shear Angles are also available on Classified Shapes, but are available as special order only.

Standard head flat and dowel locations are at 0°.

Simply add the alteration code shown next to the drawings, and the angle desired, to your punch catalog number. Tolerance on all angles is ± 15 minutes.

LL not available on XS19, XS21, XS22, and XS23.

HOW TO ORDER

Type	Code	L	P (or P&W)	Steel	Alteration
VPO	50	2332	P.400, W.300	A2	XS23 A3°

For Round Punches Only

XS19 Nail Point

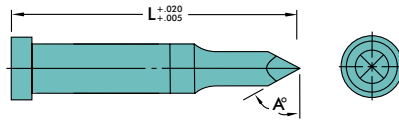

XS20 Chamfer

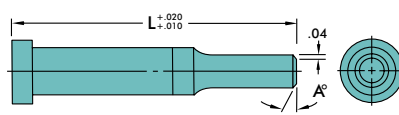

XS21 Conical

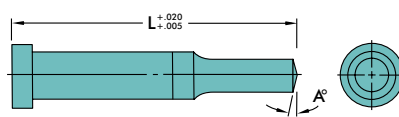

For Round & Shape Punches

Shown as reflected view.

XS22 Double Shear

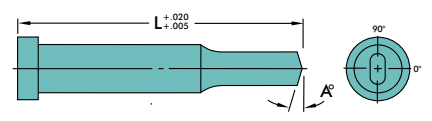

XS23 Single Shear

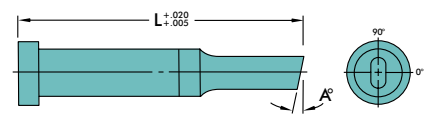

XS24 Single Shear Angle with Flat

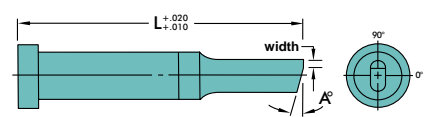

Locking Devices—Ordering Information

Orientation

The standard location for all locking devices is at 0°, and is always on the long side (P) of the shape. Custom locations are measured counterclockwise from 0°. (See drawing below.)

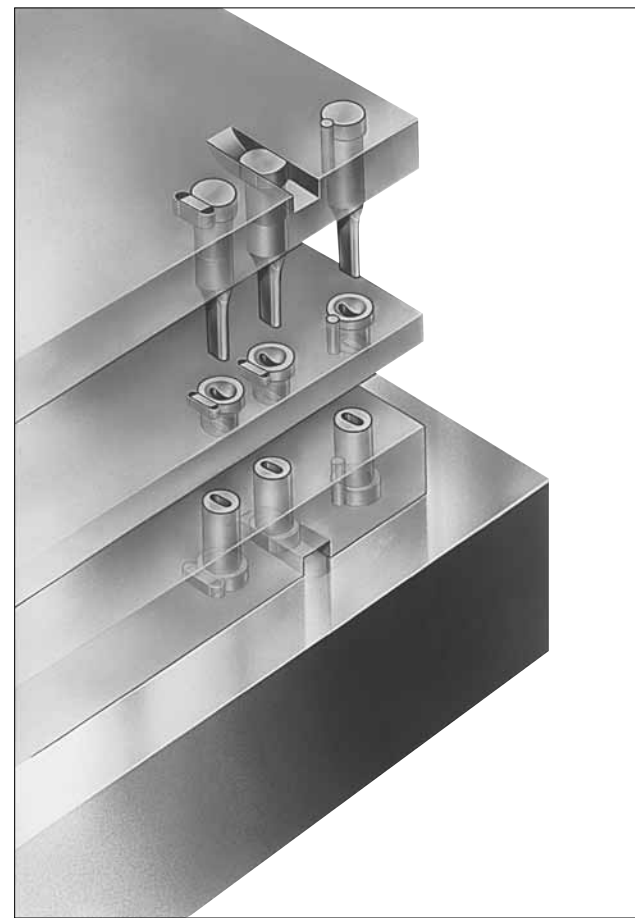
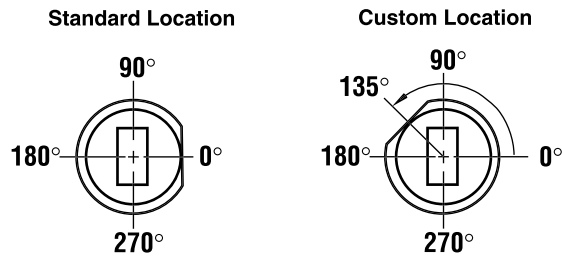

Views

A Plan View is used for the die button, and a Reflected View is used for the punch or guide. The Reflected View, a mirror image, simplifies orientation—locking devices are all in the same position.

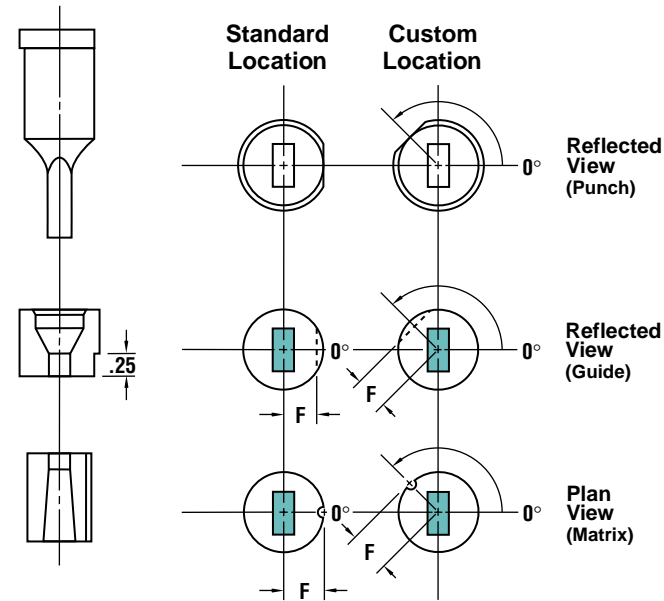
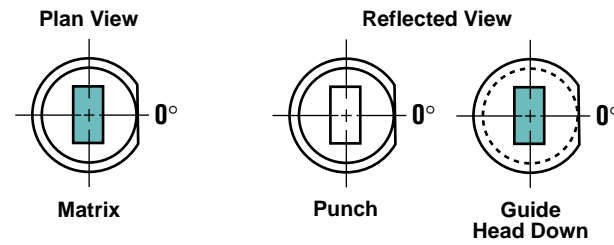

How To Specify

The most common locking devices—flat, double flat, and dowel—are available. Simply select the type, then add the code to the component description shown on p. 31.

HOW TO ORDER

Specify:	Qty.	Type	Code	L	P (or P&W)	Steel
Example:	1	VJJ	37	312	P.321, W.189	A2, X2
	3	VR0	50	137	P.3125, W.1562	A2, X2

Location Tolerance

Flat		Dowel	
F	Radial	F	Radial
+ .0002	.0005/	+ .0002	0°2'
- .0000	inch	- .0000	

Locking Devices—Flats vs. Dowel Slots

Flats

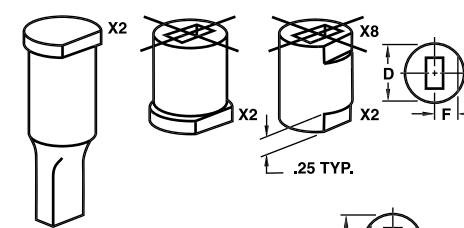

F Dimension (.5D on Headed Products)
Headless Die Buttons and Guides

Body Dia.	18	25	31	37	43	50
F	.080	.110	.135	.165	.190	.220
Body Dia.	62	75	87	100	125	150
F	.270	.325	.380	.435	.540	.650
Body Dia.	175	200	225	250	275	
F	.775	.900	1.025	1.150	1.275	

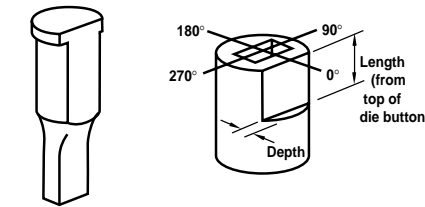

The depth of the flat is taken from the shank, not the head, on punches.

Key Flats vs. Dowel Slots

Maximum hole dimensions in die buttons were designed with key flats in mind. There are instances where, if using a dowel slot in a headless die button, the dowel hole could break into the relief. For this reason, there are two ways to specify the location of the dowel. **X0** (standard/alternate location) and **X1** (custom location) are located .5D from centerline. However, when hole dimensions are approaching the high limit of "P," **X4** (standard/alternate location) or **X7** (custom location) may be specified. This relocates the dowel outward to assure no interference between the dowel and the relief hole. Note: When the die button diameter is over .5000, the centerline dimension is .5D on all dowels.

To determine if you have an interference problem, see pp. 18-19 for information on Die Button construction.

Dowel Slots

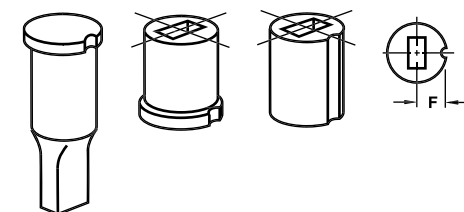

Standard & Alternate Locations

Standard Location is at 0°. **Alternate Location** is 90°, 180°, or 270°. Alternate Locations are available at no additional charge.

Single Flats: X2 & X8

Locking Devices	Punches	Die Buttons
X2	Top	Bottom
X8	N/A	Top

Order Example:
X2 — 90°

Double Flats: X3

Locking Devices	Punches	Die Buttons
X3	Top	Bottom

Order Example:
X3 — 90°

Second Flat is *always parallel* to the first flat.

Additional Flats (From Top)

Code	Depth	Length
X81*	.060	.500
X82*	.060	.625
X83*	.060	.750
X84	.060	Full Length
X85*	.093	.500
X86*	.093	.625
X87*	.093	.750
X88	.093	Full Length
X89*	Specify Dimensions	

* not available on headed die buttons (X89 available only if flat is full length).

Dowel Slots: X0**, X4, X41 & X43

Locking Devices	Dowel Diameter
X0**	.1250
X4	.1250
X41	.1875
X43	.2500

Order Example: X0 — 180°

**available on headless die buttons only

Custom Locations

Custom Location is *any angle other than*: 0°, 90°, 180°, or 270°.

Single Flats: X5 & X9

Locking Devices	Punches	Die Buttons
X5	Top	Bottom
X9	N/A	Top

Order Example:
X5 — 135°

Double Flats: X6

Locking Devices	Punches	Die Buttons
X6	Top	Bottom

Order Example:
X6 — 135°

Additional Flats (From Top)

Code	Depth	Length
X91*	.060	.500
X92*	.060	.625
X93*	.060	.750
X94	.060	Full Length
X95*	.093	.500
X96*	.093	.625
X97*	.093	.750
X98	.093	Full Length
X99*	Specify Dimensions	

* not available on headed die buttons (X99 available only if flat is full length).

Dowel Slots: X1**, X7, X71 & X73

Locking Devices	Dowel Diameter
X1**	.1250
X7	.1250
X71	.1875
X73	.2500

Order Example: X71 — 135°

F Dimension for Headed Punches and Die Buttons

$$F = .5D + .5 \text{ Dowel Dia.}$$

F Dimension for Headless Die Buttons Only

Body Diameter	25	31	37	43	50	62	75	87	100	125-400
X0, X1	.1250	.1562	.1875	.2188	.2500	.5D	.5D	.5D	.5D	.5D
X4, X7	.1625	.1875	.2125	.2375	.2625	.5D	.5D	.5D	.5D	.5D
X41, X71	.1938	.2188	.2438	.2688	.2938	.5D	.5D	.5D	.5D	.5D
X43, X73	.2250	.2500	.2750	.3000	.3250	.3438	.4063	.4688	.5313	.5D

Form Punch Shapes

Dayton Progress Form Punches are available on round punches (i.e., those designated as standard "X" shaped punches). When ordering, change the "X" designator to a "W." In addition, specify other dimensions, as shown in

the example below. Specify alterations, if applicable. The shapes shown below are standard, but are not the only shapes Dayton provides. Others are available with a detailed drawing attached to the order.

Form Punches are also available on standard punch blanks. Form Punches other than those are available as specials.



HOW TO ORDER

Specify: Qty. Type Code L Steel W Shape P PP LA Alterations
Example: 2 VPW 37 1322 PS W201 P.1875 PP.1250 LA2.235 XNT

"P" is the point dimension of the product. The "P" dimensions are not shown below. When "P" = "D," shank tolerance applies.

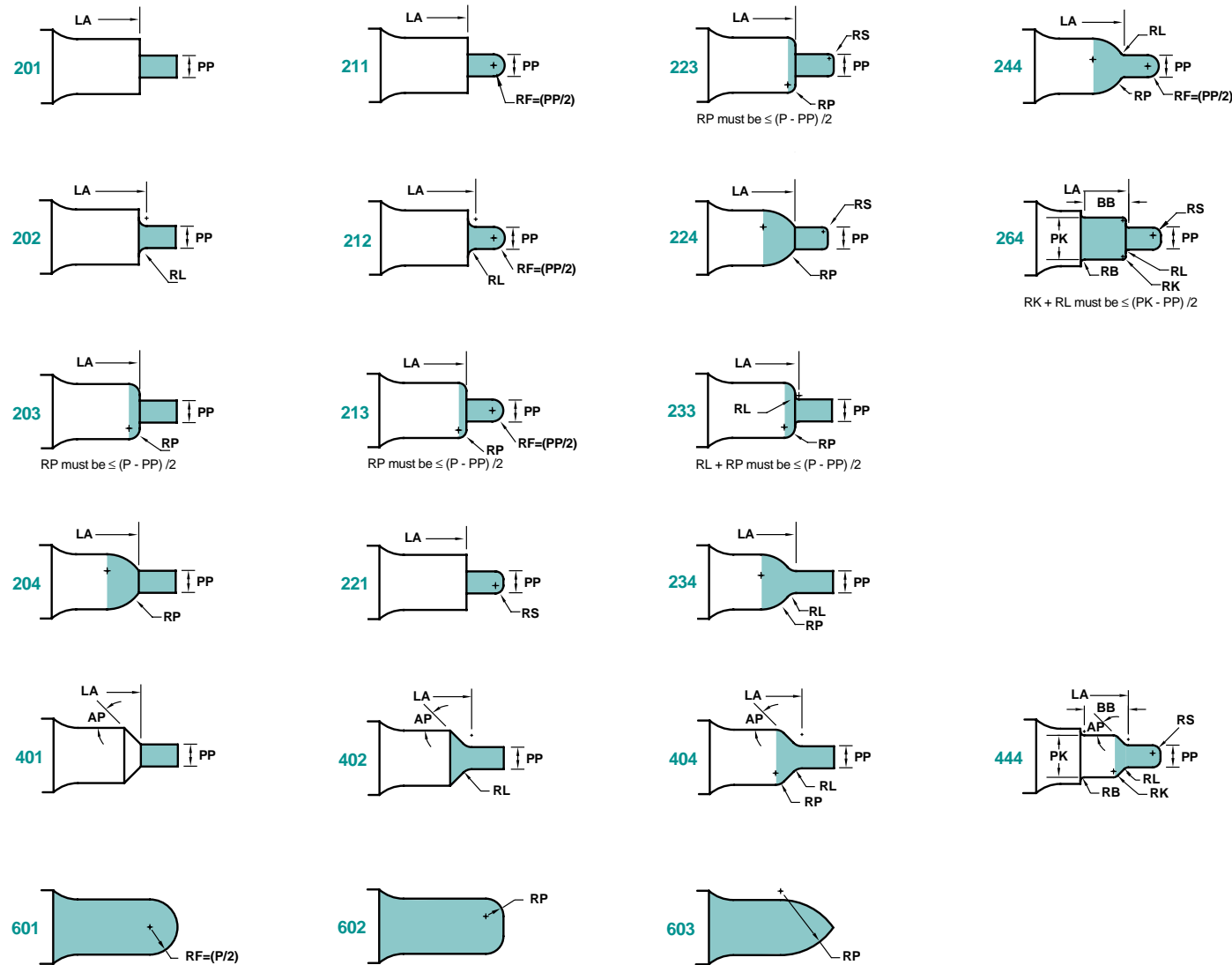
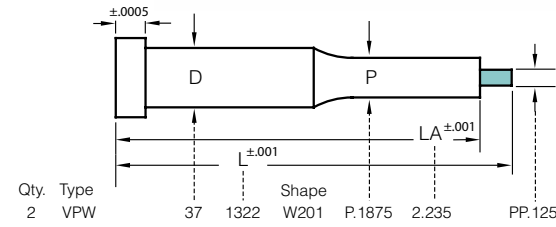

Form Punch Shapes

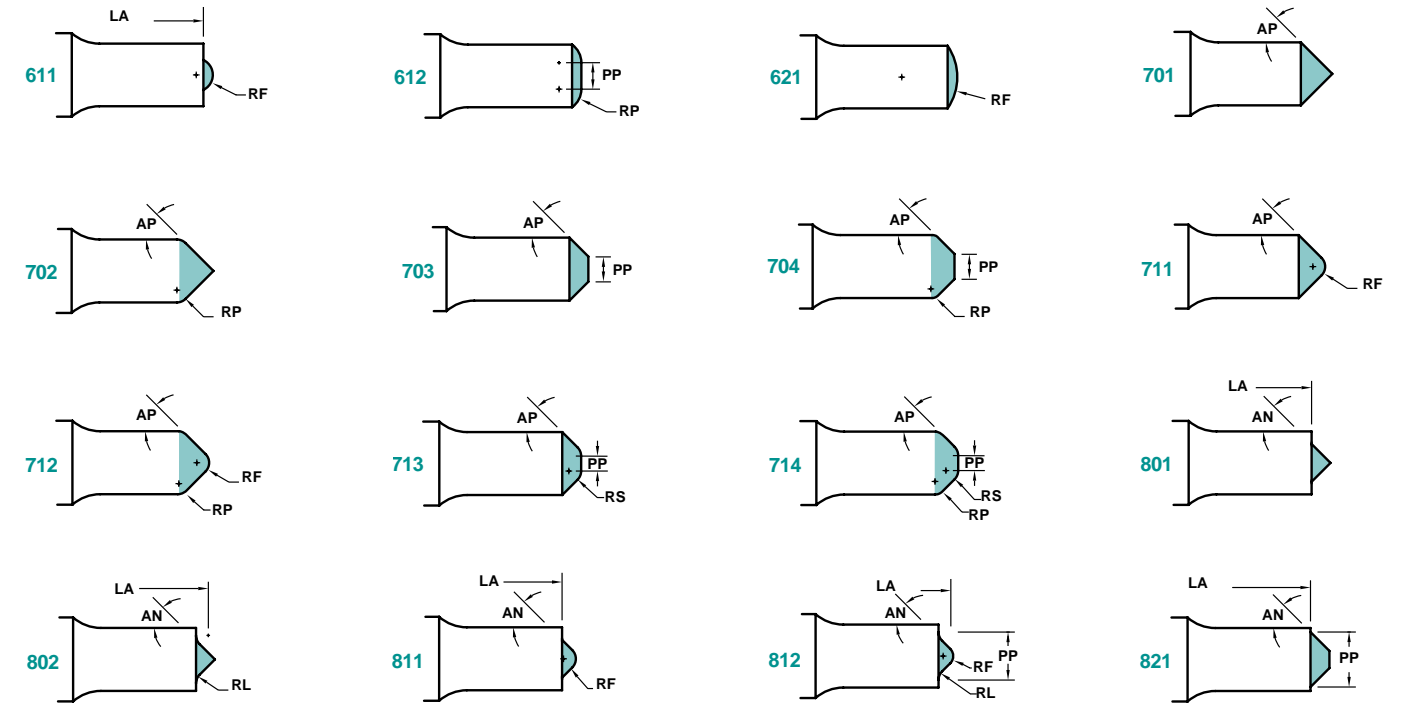

Form Die Button Shapes

Dayton Die Buttons are available for all the Form Punches shown here, i.e., round punches designated as standard "X" shaped punches. When ordering, please

change the "X" designator to a "W." Die Buttons are available as headed or headless with a counterbore relief, or as headed or headless with a tapered relief.

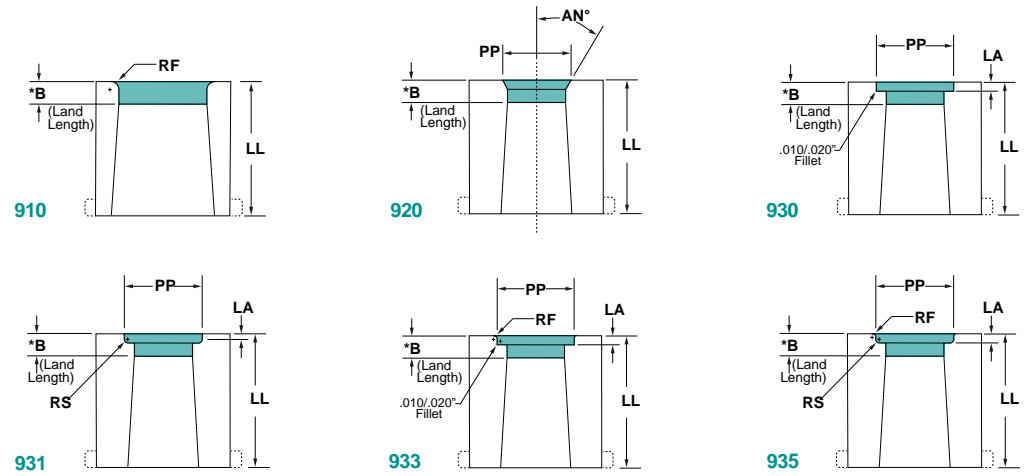

*B (Land Length) will be per catalog standard, unless XB is ordered. O.A.L. will be held to LL tolerance, i.e., ±.001.

HOW TO ORDER

Specify: Qty. Type Code LL Steel W Shape P PP LA RS RF AN° Alterations
Example: 4 VNW 100 100 M2 W935 .50 .625 .15 .05 .03 AN° XNT



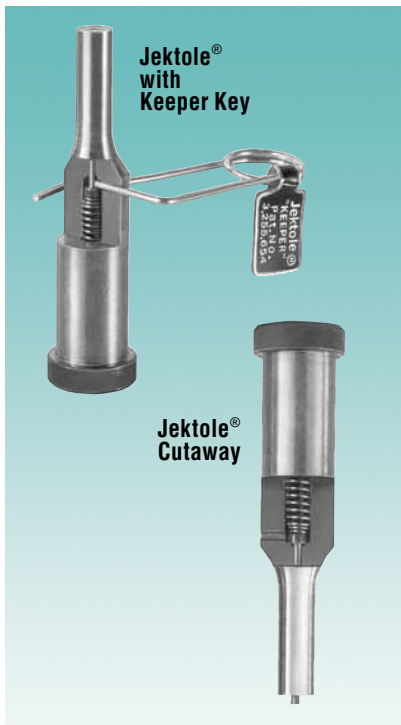

The Engineered Clearance

Perforating punch-to-die button clearances in metal stamping dies has been universally expressed as a percentage of stock thickness, and for clarity should be articulated as percent per side (Δ = clearance per side).

Standard practice has called for $\Delta 5\%$, and is commonly known as "regular clearance." Regular clearance has been applied almost universally to all applications involving the perforation of ferrous materials.

Jektole®, the **Engineered Clearance**, is approximately twice regular clearance, i.e., $\Delta 10-12\%$. This means greater productivity, improved maintenance, and a better return on your tooling investment.

In addition, clearances of up to $\Delta 50\%$ are not uncommon with some hard materials. Clearance tests have been performed by Dayton Progress to prove that increasing the clearance does not lessen hole quality—a common thought by some designers and engineers. Dayton clearance tests do, in fact, prove that the Jektole® **Engineered Clearance** provides many advantages and benefits.

Jektole® Components

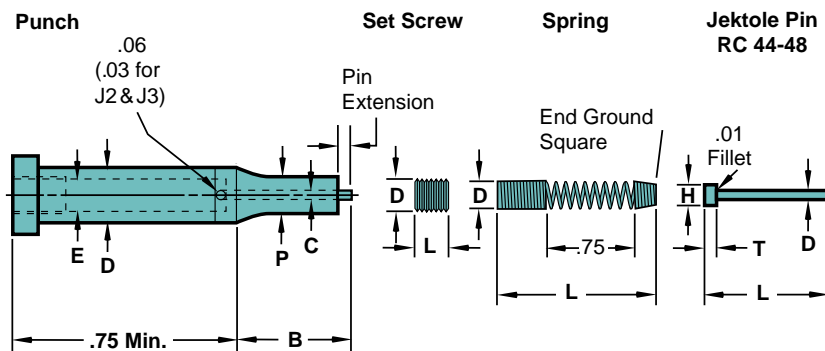

Jektole® In Production

- Requires less press tonnage
- Reduces the pressure required to strip the punch, which, in turn, reduces punch wear
- Produces minimal burr
- Doubles—often triples—piece output per grind
- Reduces total punch costs

Jektole® In Maintenance

- Keeper Key holds pin in retracted position (see photo at left)
- Eliminates the need for disassembly before grinding
- Helps maintain proper pin extension
- Reduces downtime for regrinding

Standard Jektole® Data

DIMENSION		J2	J3	J4	J6	J9	J12
Std. Shank Diameter	D	.1875	.2500	.3125	.3750 .4375 .5000	.6250 .7500 1.000	1.250 and larger
	C	.020	.032	.046	.063	.094	.125
Point Hole Diameter	C	.020	.032	.046	.063	.094	.125
Shank Hole Diameter	E	.086	.109	.141	.172	.221	.275
Pin Extension		.03	.03	.06	.06	.06	.06
Keeper Key Number		920045			920053		*

* Keeper Key not available

Jektole® Design Limits

DIMENSION		J2	J3	J4	J6	J9	J12
Min. Shank Dia.	D	.172	.218	.282	.344	.442	.552
Min. Point Dia.	P	.040	.064	.092	.126	.188	.250
Max. Point Lgth.	B	1.25	1.50	1.62	1.62	1.62	1.62

Universal Jektole® Components

EJECTOR PINS		J2	J3	J4	J6	J9	J12
Overall Length	L	1.11	1.38	1.94	1.94	2.22	2.22
Pin Diameter	D	.017	.027	.041	.058	.089	.120
Head Diameter	H	.048	.073	.094	.120	.156	.188
Hd. Thickness	T	.031	.047	.062	.062	.094	.094
SPRINGS		J2	J3	J4	J6	J9	J12
Outside Dia.	D	.081	.104	.136	.167	.216	.270
Free Length	L	2.38	2.38	3.19	3.00	3.03	2.56
Pressure (.12" Pre-load)	lbs.	.5	.75	1	1.5	2	2.5
SCREWS		J2	J3	J4	J6	J9	J12
Screw Size	D	#3-48	#5-40	#8-32	#10-32	1/4-28	5/16-24
Screw Length	L	.19	.19	.19	.19	.25	.25

Commitment to Quality & Customer Satisfaction

Dayton Lamina is a leading manufacturer of tool, die and mold components for the metal-working and plastics industries. As a customer-focused, world-class supplier of choice, we provide the brands, product breadth, distribution network and technical support for all your metal forming needs.

Our goal is to give our customers the most innovative and value-added products and services.



DAYTON Lamina™

a MISUMI Group Company



Lamina® LEMPCO

*Dayton Lamina's line of Danly products is available only to North America.



SOCIO COMERCIAL EN MÉXICO

Oficina Matriz

Av. Regio Parque #200, Regio Parque Industrial,
Apodaca N.L. C.P. 66633



www.acatmexicana.com



acat@acatmexicana.com



TEL. 81 8354 8910